

MC405

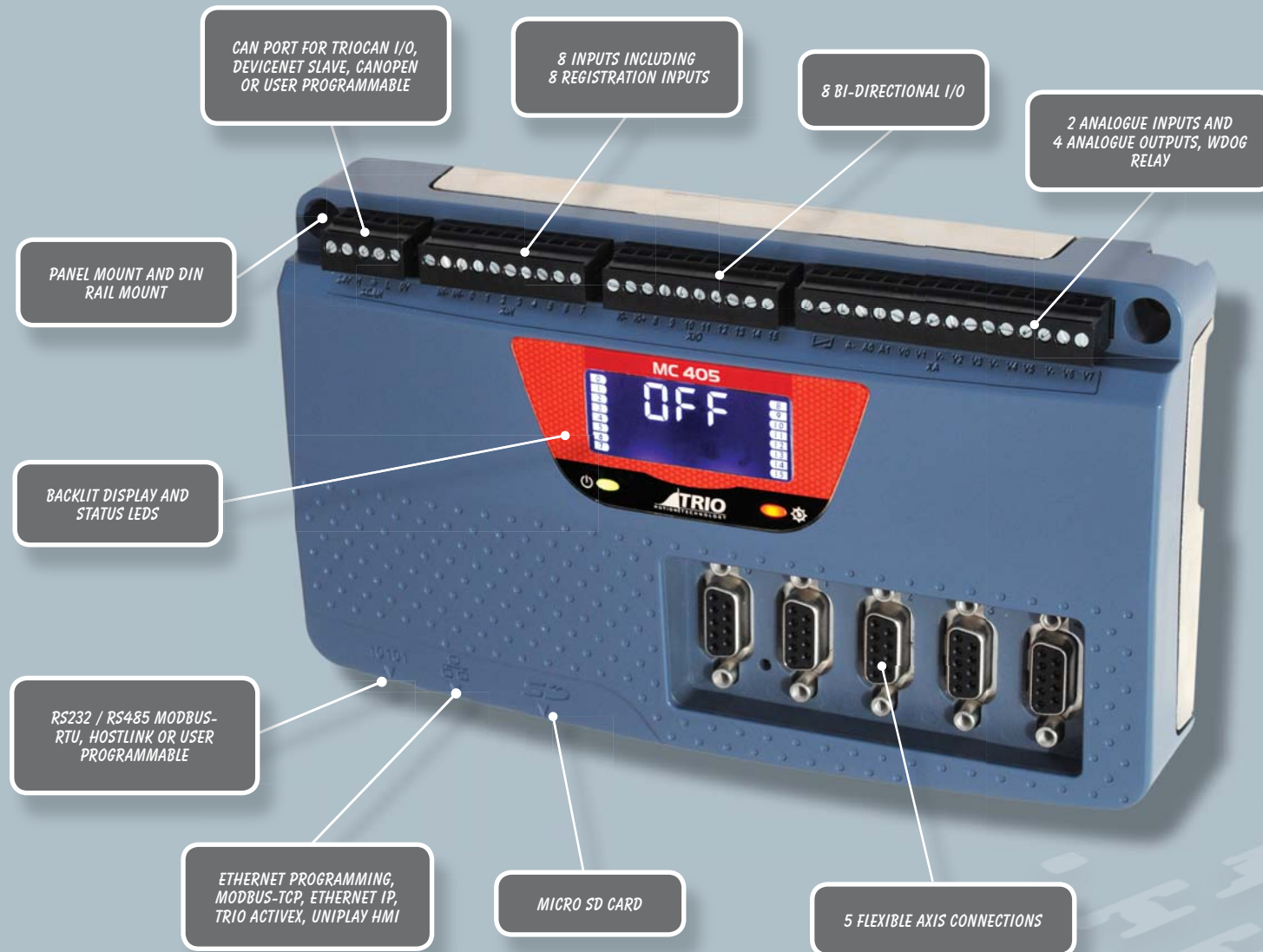

FEATURES

- * Advanced 4 Axis Closed Loop Servo / 5 Axis Pulse Direction
- * Linear, Circular, Helical and Spherical Interpolation
- * Flexible CAM shapes, Linked Motion
- * EnDAT and SSI Absolute Encoder Supported
- * Hardware Linked Outputs for Camera / Laser Control
- * Ethernet-IP / Modbus TCP / Ethernet Interface Built-In
- * 125 – 2000 μ sec Selectable Servo Update
- * Precise 64 bit Motion Calculations on ARM11 Processor with VFP
- * IEC 61131-3 Programming
- * Multi-tasking BASIC Programming
- * Text File Handling
- * Robotic Transformations
- * Micro SD Memory Card Slot
- * CANopen I/O Expansion
- * Backlit LCD Display
- * RoHS, UL and CE Approved

The MC405 is a high specification *Motion Coordinator* using a high performance ARM11 processor, with five flexible axis ports and four Voltage outputs.

The flexible axis ports can be configured in software as feedback devices or pulse direction outputs. As outputs they can be used as pulse and direction with stepper or servo drives or they can operate as a simulated encoder output. When configured as feedback they can be either incremental encoder input or one of three popular absolute encoder types; SSI, Tamagawa or Endat. Any feedback axis with a voltage output can be used to form a closed loop servo.

The built-in Ethernet port allows programming and connection of common HMI and PLC protocols directly to the MC405. User programs can be written in Trio's established multi-tasking TrioBASIC language using the powerful *Motion Perfect v3* application development software making complex motion easy. Also available are the industry standard IEC 61131-3 languages allowing a fully functional PLC programming system.

The MC405 is available in 2 different axis configurations. Both models feature a total of 16 axes in software. Any axes not assigned to built-in hardware can be used as a virtual axis. Every axis can be programmed to move using linear, circular, helical or spherical interpolation, electronic cams, linked axes and gearboxes.

A bright easy to read backlit display enables the controller status to be easily determined, whilst the single piece metal cast backplate provides an integrated earth chassis to improve noise rejection in the industrial environment.

ACCESSORIES:

| | |
|-------------|------------------------|
| P317 - P327 | CAN Modules |
| P750 | Kinematic Runtime FEC |
| P843 - P844 | UNIPLAY 7" & 10" HMI's |

OVERALL DIMENSIONS:

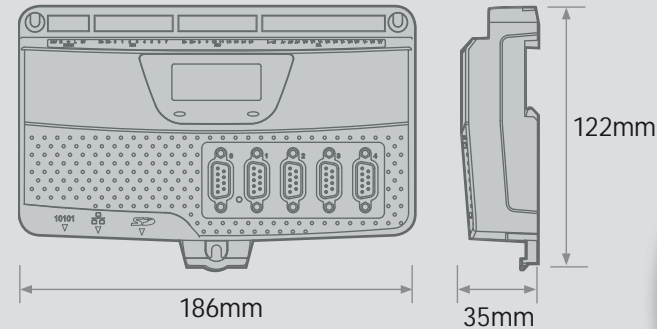

MC405 PRODUCT OPTIONS

| | P826 | P827 |
|--------|------|---------------|
| Axis 0 | Core | Extended + AS |
| Axis 1 | Core | Extended + AS |
| Axis 2 | Core | Extended + AS |
| Axis 3 | Core | Extended + AS |
| Axis 4 | Core | Extended |

CORE AXES – can be configured in software as pulse and direction outputs to stepper or servo drives. They can also be configured for incremental encoder feedback or simulated encoder output.

EXTENDED AXES – in addition to the Core functionality these axes can also be configured for SSI, Tamagawa or EnDat absolute encoders.

AS - Analogue 'closed loop' Servo using built-in $\pm 10V$ analogue output.

